



PRODUCT INFORMATION

Part #: **CE-HM630KQS**

Revision: 3-2012



DESCRIPTION		FEATURES			
Challenge Electronics CHIME Tone, MEDIUM Loud, 6 to 30 Vdc, K style case Flange Rear Panel Mounting in 1.125" (28.6 mm) Hole, Sound Pressure Level of 94 dB(A) at 30 Vdc at 61 cm, 2,900 Hz. Output Frequency, Quick Connect Blades termination, Slow Rate 1 pulse per second, Piezoelectric Alarm, RoHS Compliant		<ul style="list-style-type: none"> ◆ Reliable Solid State Piezoelectric Technology ◆ Corrosion resistant Stainless Steel Diaphragm ◆ Flame Retardant Plastic ◆ Extended storage temperature ◆ Hermetically Sealed Alarm ◆ Water Proof, NEMA 3R, 4X, or 12 with Gasket (not supplied) ◆ RoHS, Lead Free Compliance ◆ ISO 9001 Certified 			
SPECIFICATIONS					
Operating Mode	Medium Loud, Slow Chime Tone	Pulse Rate	1 ± 10% Pulse per Second		
Operating Voltage	6 to 30 Vdc	Nominal Operating Voltage	24 Vdc		
Operating Frequency	2,900 ± 250 Hz.				
Typical Loudness	At Minimum Voltage	78 ± 5 dB(A), at 6 Vdc, 24 inches (61 cm), 25°C			
	At Maximum Voltage	94 ± 3 dB(A), at 30 Vdc, 24 inches (61 cm), 25°C			
Typical Operating Current	At Minimum Voltage	10 mA at 6 Vdc	At Maximum Voltage	40 mA at 30 Vdc	
	Operating Temperature	-30°C to +65°C		Storage Temperature	-40°C to +105°C
Surge Voltage	20% over maximum Operating Voltage for less than 5 minutes				
Materials	Alarm Case	Plastic, "K" Case, NORYL™, PX9406 or equal, flame retardant UL 94-V0, Black			
	Diaphragm	Stainless Steel 304			
	Encapsulation	Two parts epoxy resin or silicone potting, Black			
	Termination	Two, 0.25 (6.4 mm) Quick Connect Blades, 0.032Ø (0.8Ø mm) Wide, Brass, Electro-Tin plated			
Physical Dimensions	Length or Diameter (L / D)	1.46" (37.1 mm) Ø	Long (L)	1.86" (47.2 mm)	Height (H) 0.86" (21.8 mm)
Approximate Weight	28 grams	Removable Washing Label	No	Compliance	RoHS
Available Options					
RELIABILITY					
Thermal Operating Temperature Test	240 hours continuous operation at Rated Power, at Maximum Rated Operating Temperature *				
	240 hours continuous operation at Rated Power, at Minimum Rated Operating Temperature *				
Thermal Storage Temperature Test	96 hours storage at Maximum Rated Storage Temperatures *				
	96 hours storage at Minimum Rated Storage Temperatures *				
Thermal Shock Test	5 cycles of Minimum and Maximum Operating Temperature Each cycle shell be set per diagram below and is 3 hours long *				
Humidity Test	120 Hours at +60°C±2°C. 90-95% RH *				
Salt Spray	Withstand exposure to salt spray per ASTM B117 for a period of 300 hours *				
Water & Dust Exposure	Withstands water submergence and dust exposure per IP-68 *				
Vibration Test	2 Hours at 1.5 mm with 10 to 55 Hz. of vibration frequency to each of 3 perpendicular direction *				
Drop Test	Dropped naturally from 1 meter height onto the surface of 10mm wooden board, 2 directions upper and side of the part are applied *				
Termination Strength	Maximum of 15 pounds (6.8 Kg) load pull test				
* Reliability Test Performance	Parts should conform to original performance within ±3dB, after 3 hours of recovery and dry period				
Life Test	Intermittent	1,000 hours of a 1 minute on 4 minutes off cycle at room temperature and maximum rated voltage			
	Continuous	250 hours continuous operation at maximum rated Voltage and maximum Operating Temperatures			
Warranty	For a period of one (1) year from date of shipping under normal operations conditions This warranty does not apply to products damaged through misuse, abuse, improper installation, alteration, rework, or attempt to repair				

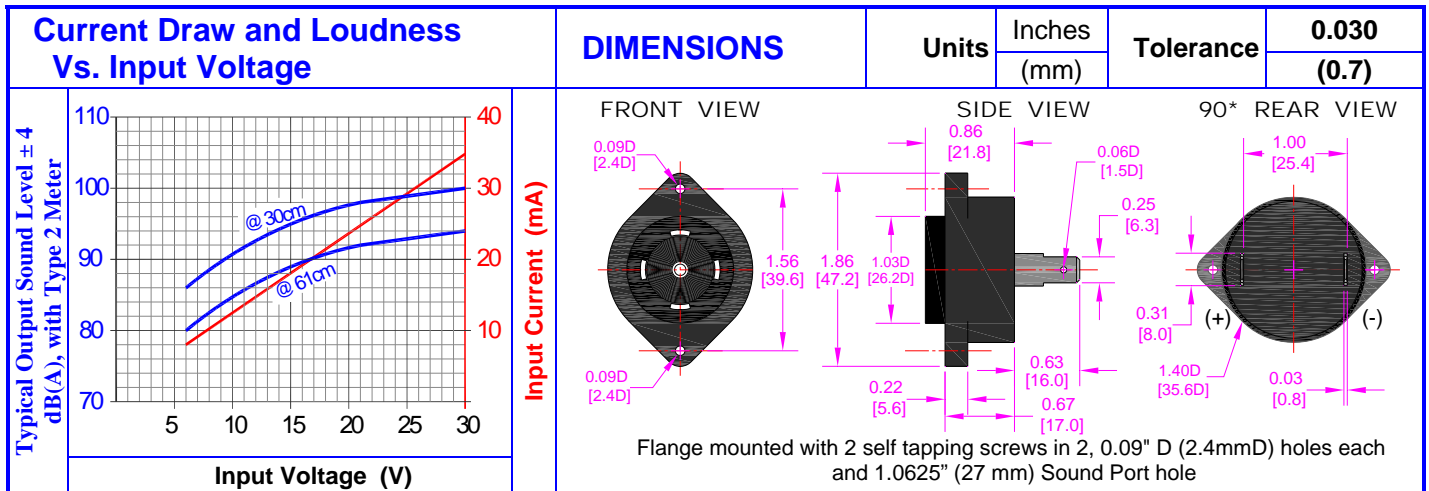

PACKAGING

ONE TRAY:

TWO BUNDLE

ONE BUNDLE:

SHIPPING BOX

MODEL	
QTY	PCS
N.W	KG
G.W	KG
SIZE	
LOT NO	

MARKING	TRAY	
Bundle	Dimensions	X1 34.7 cm
Customer PN		Y1 34.7 cm
Other PN if required		Z1 21.2 cm
Quantity	Quantity	42
Lot and/or Date Code	BUNDLE	
Bundle Number	Dimensions	X2 cm
Shipping Box		Y2 cm
Customer Part Number		Z2 cm
Other PN (if required)	Quantity	
Quantity	SHIPPING BOX	
Lot and/or Date Code	Dimensions	X3 35 cm
PO Number		Y3 35 cm
Net Weight		Z3 22.5 cm
Gross Weighjt	Number of Bundles	1
Box Number	Quantity	250
of Number of Boxes	Approximate Weight	9 Kg.
Made in China		

The information contained herein is believed to be correct, but no guarantee or warranty, express or implied, with respect to accuracy, completeness or results is extended and no liability is assumed.
 Challenge Electronics reserves the right to make changes in any specification, data or material contained herein.