



PRODUCT INFORMATION

Part #: CE-HM948ALS

Revision: 3-2012



DESCRIPTION		FEATURES			
Challenge Electronics Custom made; CHIME Tone; MEDIUM Loud; A Style case; 9 to 48 Vdc; 2,900 Hz. Frequency; 98 dB at 61 cm 36 Vdc; L shape 0.25" Quick Disconnect Blades Termination; Slow 1 Pulse per second Rate; Piezoelectric Alarm		<ul style="list-style-type: none"> ◆ Reliable Solid State Piezoelectric Technology ◆ Corrosion resistant Stainless Steel Diaphragm ◆ Flame Retardant Plastic ◆ Extended storage temperature ◆ Hermetically Sealed Alarm ◆ Water Proof, NEMA 3R, 4X, or 12 with Gasket (not supplied) ◆ RoHS, Lead Free Compliance ◆ ISO 9001 Certified 			
SPECIFICATIONS					
Operating Mode	Medium Loud, Slow Chime Tone		Chime Rate	1 ± 10% Pulse per second	
Operating Voltage	9 to 48 Vdc		Nominal Operating Voltage	36 Vdc	
Operating Frequency	2,900 ± 250 Hz.				
Sound Pressure Level	At Minimum Voltage	80 ± 6 dB(A) at: 9 Vdc, 24 inches (61 cm), 25°C			
	At Maximum Voltage	96 ± 4 dB(A) at: 48 Vdc, 24 inches (61 cm), 25°C			
Maximum Current	At Minimum Voltage	10 mA at 9 Vdc		At Maximum Voltage	30 mA at 48 Vdc
Operating Temperature	-30°C to +65°C		Storage Temperature	-40°C to +100°C	
Surge Voltage	10% over maximum Operating Voltage for less than 1 minutes				
Materials	Alarm Case	Plastic, "A" Case, NORYL™, PX9406 or equal, flame retardant UL 94-V0, Black			
	Diaphragm	Stainless Steel 304			
	Encapsulation	Two parts epoxy resin and/or silicone potting, Black			
	Termination	Two (2), 0.25 (6.4 mm) Quick Disconnect Blades, 0.032" (0.8mm) thick, Brass, Electro-Tin plated Termination must fit Delphi Connector PE 2973385			
Physical Dimensions	Length or Diameter (L /D)	1.40" (35.6 mm) Ø	Width (W)	Height (H)	1.41" (35.7 mm)
Approximate Weight	34 grams	Removable Washing Label	No	Compliance	RoHS
Options					
RELIABILITY					
Thermal Operating Temperature Test	240 hours continuous operation at Rated Power, at Maximum Rated Operating Temperature *				
	240 hours continuous operation at Rated Power, at Minimum Rated Operating Temperature *				
Thermal Storage Temperature Test	96 hours storage at Maximum Rated Storage Temperatures *				
	96 hours storage at Minimum Rated Storage Temperatures *				
Thermal Shock Test	5 cycles of Minimum and Maximum Operating Temperature Each cycle shall be set per diagram below and is 3 hours long *				
Humidity Test	120 Hours at +60°C ± 2°C. 90-95 % RH *				
Salt Spray	Withstand exposure to salt spray per ASTM B117 for a period of 300 hours *				
Environmental Exposure	Dust, water, salt, dust-control agents, moisture-control agents, detergents, degreasers, diesel fuel, hydraulic fluid per IP-68 *				
Vibration Test	2 Hours at 1.5 mm with 10 to 55 Hz. of vibration frequency to each of 3 perpendicular direction *				
Drop Test	Dropped naturally from 1 meter height onto the surface of 10 mm wooden board, 2 directions upper and side of the part are applied *				
Termination Strength	Maximum of 15 pounds (6.8 Kg) load pull test				
* Reliability Test Performance	Parts should conform to original performance within ± 3 dB				
Life Test	Intermittent	1,000 hours of a 1 minute on 4 minutes off cycle at room temperature and Nominal Rated Voltage			
	Continuous	250 hours continuous operation at room temperature and Nominal Rated Voltage			
Warranty	For a period of one (1) year from date of shipping under normal operations conditions This warranty does not apply to products damaged through misuse, abuse, improper installation, alteration, rework, or attempt to repair				



SPL and CURRENT Vs. INPUT VOLTAGE

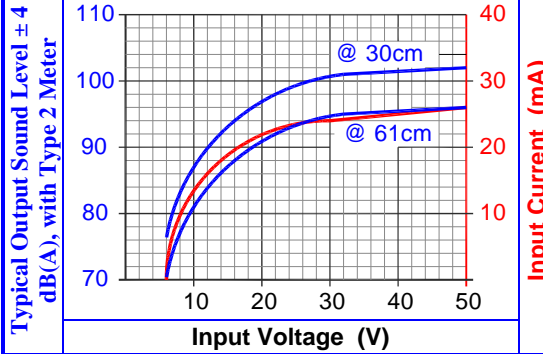

DIMENSIONS

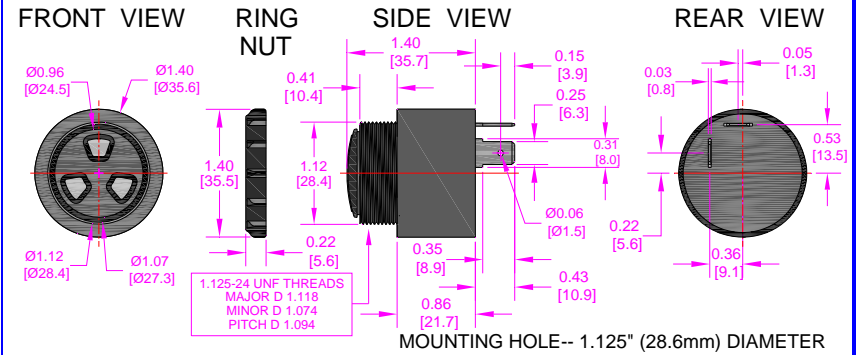

PACKAGING

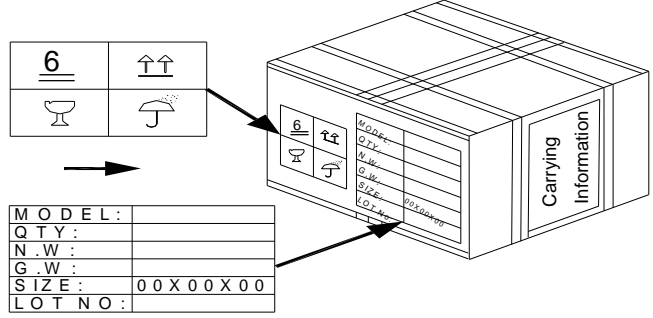
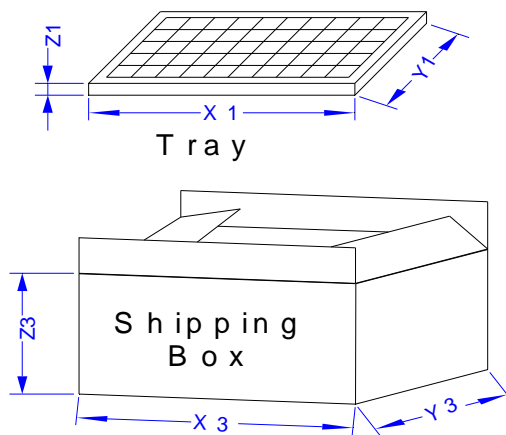

Tray		
Dimensions	X1	34.7 cm
	Y1	34.7 cm
	Z1	21.2 cm
Quantity	42	
SHIPPING BOX		
Dimensions	X2	35 cm
	Y2	35 cm
	Z2	22.5 cm
Part Number		
Customer PN (if required)		
Number of Trays		
Quantity	250 each	
Lot and/or Date Code		
PO Number		
Net Weight		
Gross Weight		
Box Number		
of Number of Boxes		
Country of Origin	Made in China	