



# PRODUCT INFORMATION

Part #: **CE-HCM948AQS**

Revision: 3-2012



DESCRIPTION		FEATURES			
<b>Challenge Electronics Dual-Function CHIME or CONTINUOUS Tones, MEDIUM Loud, 9 to 48 Vac/dc, A style</b> case Rear Panel Mounting in 1.125" (28.6 mm) Hole, Sound Pressure Level of <b>96 dB(A)</b> at 48 Vdc at 61 cm, <b>2,900 Hz</b> . Output Frequency, three <b>Quick Connect Blades</b> termination, <b>Slow Rate</b> 1 pulse per second, Piezoelectric Alarm, <b>RoHS</b> Compliant		<ul style="list-style-type: none"> <li>◆ Reliable Solid State Piezoelectric Technology</li> <li>◆ Corrosion resistant Stainless Steel Diaphragm</li> <li>◆ Flame Retardant Plastic</li> <li>◆ Extended storage temperature</li> <li>◆ Hermetically Sealed Alarm</li> <li>◆ Water Proof, NEMA 3R, 4X, or 12 with Gasket (not supplied)</li> <li>◆ RoHS, Lead Free Compliance</li> <li>◆ ISO 9001 Certified</li> </ul>			
<b>SPECIFICATIONS</b>					
Operating Mode	Medium Loud, Slow Chime or Continuous Tones		Pulse Rate	1 ± 10% Pulse per Second	
Operating Voltage	9 to 48 Vdc		Nominal Operating Voltage	36 Vdc	
Operating Frequency	2,900 ± 250 Hz.				
Typical Loudness	At Minimum Voltage	80 ± 5 dB(A), at 9 Vdc, 24 inches (61 cm), 25°C			
	At Maximum Voltage	96 ± 3 dB(A), at 48 Vdc, 24 inches (61 cm), 25°C			
Typical Operating Current	At Minimum Voltage	10 mA at 9 Vdc	At Maximum Voltage	30 mA at 48 Vdc	
Operating Temperature	-30°C to +65°C		Storage Temperature	-40°C to +105°C	
Surge Voltage	20% over maximum Operating Voltage for less than 5 minutes				
Materials	Alarm Case	Plastic, "A" Case, NORYL™, PX9406 or equal, flame retardant UL 94-V0, Black			
	Diaphragm	Stainless Steel 304			
	Encapsulation	Two parts epoxy resign or silicone potting, Black			
	Termination	Three, 0.25 (6.4 mm) Quick Connect Blades, 0.032Ø (0.8Ø mm) Wide, Brass, Electro-Tin plated			
Physical Dimensions	Length or Diameter (L/D)	1.46" (37.1 mm) Ø	Width (W)	Height (H)	1.4" (35.7 mm)
Approximate Weight	40 grams	Removable Washing Label	No	Compliance	RoHS
Available Options					
<b>RELIABILITY</b>					
Thermal Operating Temperature Test	240 hours continuous operation at Rated Power, at Maximum Rated Operating Temperature *				
Thermal Storage Temperature Test	96 hours storage at Maximum Rated Storage Temperatures *				
Thermal Shock Test	5 cycles of Minimum and Maximum Operating Temperature Each cycle shall be set per diagram below and is 3 hours long *				
Humidity Test	120 Hours at +60°C±2°C. 90-95% RH *				
Salt Spray	Withstand exposure to salt spray per ASTM B117 for a period of 300 hours *				
Water & Dust Exposure	Withstands water submergence and dust exposure per IP-68 *				
Vibration Test	2 Hours at 1.5 mm with 10 to 55 Hz. of vibration frequency to each of 3 perpendicular direction *				
Drop Test	Dropped naturally from 1 meter height onto the surface of 10mm wooden board, 2 directions upper and side of the part are applied *				
Termination Strength	Maximum of 15 pounds (6.8 Kg) load pull test				
* Reliability Test Performance	Parts should conform to original performance within ±3dB, after 3 hours of recovery and dry period				
Life Test	Intermittent	1,000 hours of a 1 minute on 4 minutes off cycle at room temperature and maximum rated voltage			
	Continuous	250 hours continuous operation at maximum rated Voltage and maximum Operating Temperatures			
Warranty	For a period of one (1) year from date of shipping under normal operations conditions This warranty does not apply to products damaged through misuse, abuse, improper installation, alteration, rework, or attempt to repair				

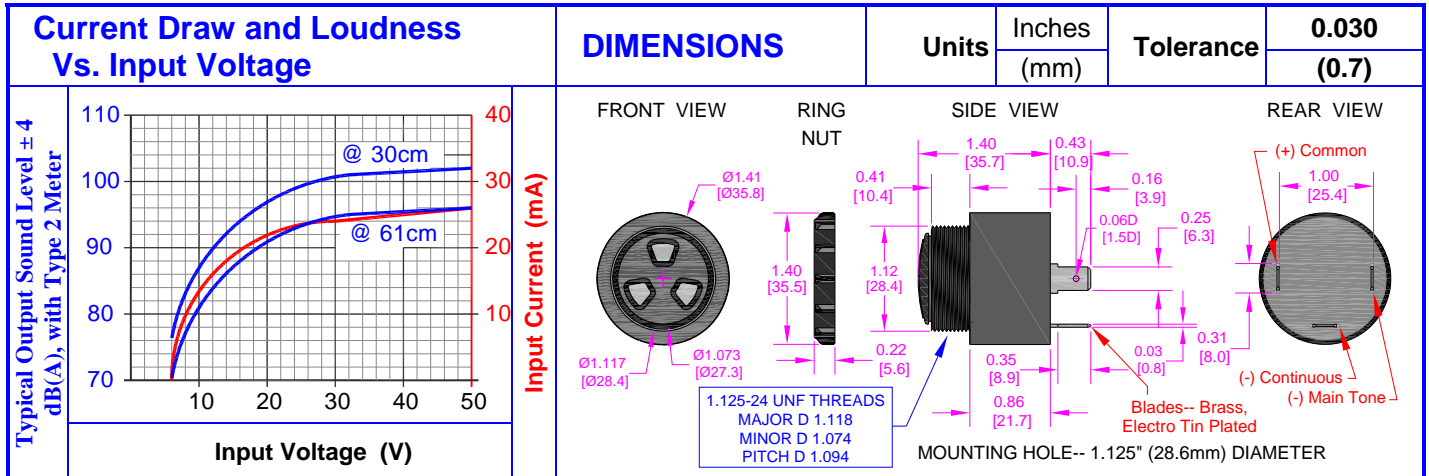

### PACKAGING

**ONE TRAY:**

**TWO BUNDLE**

**ONE BUNDLE:**

**SHIPPING BOX**

**TOP COVER**

6	↑↑
↑↑	↑↑
↑↑	↑↑
↑↑	↑↑

MODEL	PCS
QTY	KG
N.W	KG
G.W	KG
SIZE	
LOT NO	

MARKING		TRAY	
Bundle		X1	34.7 cm
Customer PN	Dimensions	Y1	34.7 cm
Other PN if required		Z1	21.2 cm
Quantity	Quantity	42	
Lot and/or Date Code	<b>BUNDLE</b>		
Bundle Number		X2	cm
Shipping Box	Dimensions	Y2	cm
Customer Part Number		Z2	cm
Other PN (if required)	Quantity		
Quantity	<b>SHIPPING BOX</b>		
Lot and/or Date Code		X3	35 cm
PO Number	Dimensions	Y3	35 cm
Net Weight		Z3	22.5 cm
Gross Weight	Number of Bundles	1	
Box Number	Quantity	250	
of Number of Boxes	Approximate Weight	10 Kg.	
<b>Made in China</b>			