



# PRODUCT INFORMATION

Part #: **CE-CX215AQ**

Revision: 5-2013



DESCRIPTION		FEATURES			
<b>Challenge Electronics CONTINUOUS Tone, EXTRA Loud, 2 to 15 Vdc, A style case Rear Panel Mounting in 1.125" (28.6 mm) Hole, Sound Pressure Level of 103 dB(A) at 15 Vdc at 61 cm, 2,900 Hz. Output Frequency, Quick Connect Blades termination, Piezoelectric Alarm, RoHS Compliant</b>		<ul style="list-style-type: none"> <li>◆ Reliable Solid State Piezoelectric Technology</li> <li>◆ Corrosion resistant Stainless Steel Diaphragm</li> <li>◆ Flame Retardant Plastic</li> <li>◆ Extended storage temperature</li> <li>◆ Hermetically Sealed Alarm</li> <li>◆ Water Proof, NEMA 3R, 4X, or 12 with Gasket (not supplied)</li> <li>◆ RoHS, Lead Free Compliance</li> <li>◆ ISO 9001 Certified</li> </ul>			
SPECIFICATIONS					
Operating Mode	Extra Loud, Continuous Tone		Pulse Rate		
Operating Voltage	2 to 15 Vdc		Nominal Operating Voltage		12 Vdc
Operating Frequency	2,900 ± 500 Hz.				
Typical Loudness	At Minimum Voltage	75 ± 5 dB(A), at 2 Vdc, 24 inches (61 cm), 25°C			
	At Maximum Voltage	103 ± 3 dB(A), at 15 Vdc, 24 inches (61 cm), 25°C			
Typical Operating Current	At Minimum Voltage	5 mA at 2 Vdc	At Maximum Voltage	30 mA at 15Vdc	
	Operating Temperature	-30°C to +65°C		Storage Temperature	-40°C to +105°C
Surge Voltage	20% over maximum Operating Voltage for less than 5 minutes				
Materials	Alarm Case	Plastic, "A" Case Style, NORYL™, PX9406 or equal, flame retardant UL 94-V0, Black			
	Diaphragm	Stainless Steel 304			
	Encapsulation	Two parts epoxy resin or silicone potting, Black			
	Termination	Two 2 0.25 (6.4 mm) Quick Connect Blades, 0.032Ø (0.8Ømm) wide, Brass, Electro-Tin plated			
Physical Dimensions	Length or Diameter (L /D)	1.40" (35.6 mm) Ø	Width (W)	Height (H)	1.40" (35.7 mm)
Approximate Weight	35 grams	Removable Washing Label	No	Compliance	RoHS
Available Options					
RELIABILITY					
Thermal Operating Temperature Test	240 hours continuous operation at Rated Power, at Maximum Rated Operating Temperature *				
	240 hours continuous operation at Rated Power, at Minimum Rated Operating Temperature *				
Thermal Storage Temperature Test	96 hours storage at Maximum Rated Storage Temperatures *				
	96 hours storage at Minimum Rated Storage Temperatures *				
Thermal Shock Test	5 cycles of Minimum and Maximum Operating Temperature Each cycle shall be set per diagram below and is 3 hours long *				
Humidity Test	120 Hours at +60°C±2°C, 90-95% RH *				
Salt Spray	Withstand exposure to salt spray per ASTM B117 for a period of 300 hours *				
Water & Dust Exposure	Withstands water submergence and dust exposure per IP-68 *				
Vibration Test	2 Hours at 1.5 mm with 10 to 55 Hz. of vibration frequency to each of 3 perpendicular direction *				
Drop Test	Dropped naturally from 1 meter height onto the surface of 10mm wooden board, 2 directions upper and side of the part are applied *				
Termination Strength	Maximum of 15 pounds (6.8 Kg) load pull test				
* Reliability Test Performance	Parts should conform to original performance within ±3dB, after 3 hours of recovery and dry period				
Life Test	Intermittent	1,000 hours of a 1 minute on 4 minutes off cycle at room temperature and maximum rated voltage			
	Continuous	250 hours continuous operation at maximum rated Voltage and maximum Operating Temperatures			
Warranty	For a period of one (1) year from date of shipping under normal operations conditions This warranty does not apply to products damaged through misuse, abuse, improper installation, alteration, rework, or attempt to repair				

The information contained herein is believed to be correct, but no guarantee or warranty, express or implied, with respect to accuracy, completeness or results is extended and no liability is assumed.  
 Challenge Electronics reserves the right to make changes in any specification, data or material contained herein.

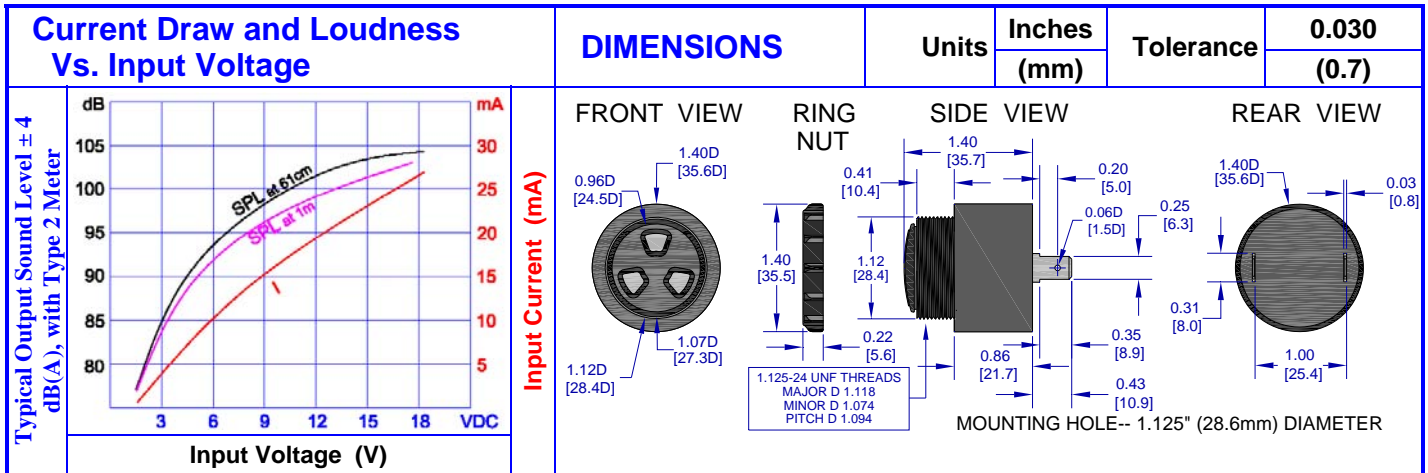

**PACKAGING**

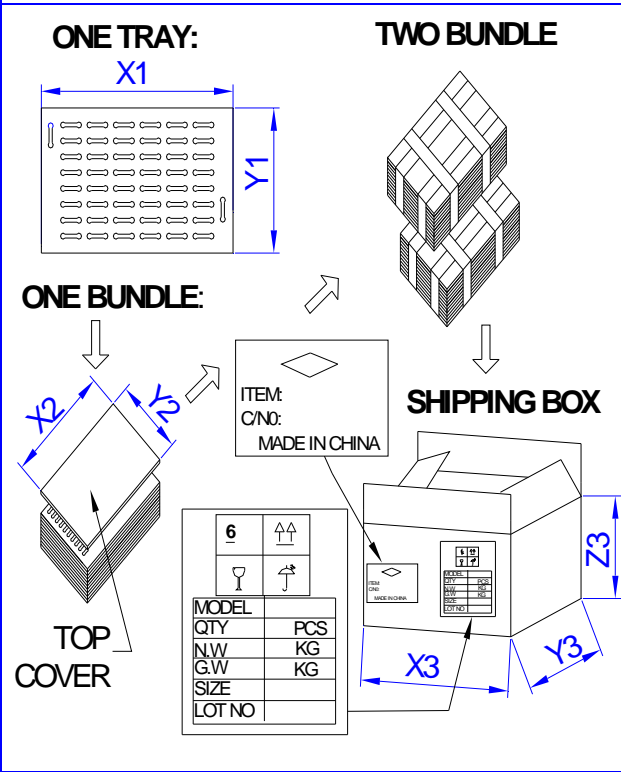

MARKING	TRAY	
Bundle		
Part Number	Dimensions	X1 34.7 cm
Other PN if required		Y1 34.7 cm
Quantity	Quantity	Z1 21.2 cm
Lot and/or Date Code	BUNDLE	
Bundle Number		X2 cm
Shipping Box	Dimensions	Y2 cm
Part Number		Z2 cm
Other PN (if required)	Quantity	
Quantity	SHIPPING BOX	
Lot and/or Date Code		X3 35 cm
PO Number	Dimensions	Y3 35 cm
Net Weight		Z3 22.5 cm
Gross Weighjt	Number of Bundles	1
Box Number of Boxes	Quantity	250
Made in China	Approximate Weight	9 Kg.

Revision	Description	By	Date
5-2013	Revised Operating Temperature	Ely Zofan	6/25/2013

The information contained herein is believed to be correct, but no guarantee or warranty, express or implied, with respect to accuracy, completeness or results is extended and no liability is assumed.  
 Challenge Electronics reserves the right to make changes in any specification, data or material contained herein.