



PRODUCT INFORMATION

Part #: **CE-WCM530ASS**

Revision: 3-2012



DESCRIPTION		FEATURES			
Challenge Electronics Dual-Function WARBLE or CONTINUOUS Tones, MEDIUM Loud, 5 to 30 Vdc, A style case Rear Panel Mounting in 1.125" (28.6 mm) Hole, Sound Pressure Level of 98 dB(A) at 30 Vdc at 61 cm, 2,900 Hz . Output Frequency, S two 0.25" (6.4 mm) Blades with M3 0.25" (6.4 mm) long Stainless Steel Screws termination, Slow Rate 1 Cycle per second, Piezoelectric Alarm, RoHS Compliant		<ul style="list-style-type: none"> ◆ Reliable Solid State Piezoelectric Technology ◆ Corrosion resistant Stainless Steel Diaphragm ◆ Flame Retardant Plastic ◆ Extended storage temperature ◆ Hermetically Sealed Alarm ◆ Water Proof, NEMA 3R, 4X, or 12 with Gasket (not supplied) ◆ RoHS, Lead Free Compliance ◆ ISO 9001 Certified 			
SPECIFICATIONS					
Operating Mode	Medium Loud, Slow Warble or Continuous Tones	Pulse Rate	1 ± 10% Cycle per Second		
Operating Voltage	5 to 30 Vdc	Nominal Operating Voltage	24 Vdc		
Operating Frequency	Center Frequency 2,900 ± 250 Hz.; cycles approximately ± 300 Hz. From Center Frequency				
Typical Loudness	At Minimum Voltage	85 ± 5 dB(A), at 5 Vdc, 24 inches (61 cm), 25°C			
	At Maximum Voltage	98 ± 3 dB(A), at 30 Vdc, 24 inches (61 cm), 25°C			
Typical Operating Current	At Minimum Voltage	5 mA at 5 Vdc	At Maximum Voltage	25 mA at 30 Vdc	
	Operating Temperature	-30°C to +65°C		Storage Temperature	-40°C to +105°C
Surge Voltage	20% over maximum Operating Voltage for less than 5 minutes				
Materials	Alarm Case	Plastic, "A" Case, NORYL™, PX9406 or equal, flame retardant UL 94-V0, Black			
	Diaphragm	Stainless Steel 304			
	Encapsulation	Two parts epoxy resign or silicone potting, Black			
	Termination	Three, 0.25 (6.4 mm) Quick Connect Blades, 0.032Ø (0.8Ø mm) Wide, Brass, Electro-Tin plated With M3 0.25" (6.4 mm) long Stainless Steel Screws.			
Physical Dimensions	Length or Diameter (L/D)	1.46" (37.1 mm) Ø	Width (W)	Height (H)	1.4" (35.7 mm)
Approximate Weight	40 grams	Removable Washing Label	No	Compliance	RoHS
Available Options					
RELIABILITY					
Thermal Operating Temperature Test	240 hours continuous operation at Rated Power, at Maximum Rated Operating Temperature *				
Thermal Storage Temperature Test	240 hours continuous operation at Rated Power, at Minimum Rated Operating Temperature *				
Thermal Shock Test	96 hours storage at Maximum Rated Storage Temperatures *				
	96 hours storage at Minimum Rated Storage Temperatures *				
Thermal Shock Test	5 cycles of Minimum and Maximum Operating Temperature Each cycle shall be set per diagram below and is 3 hours long *				
Humidity Test	120 Hours at +60°C±2°C. 90-95% RH *				
Salt Spray	Withstand exposure to salt spray per ASTM B117 for a period of 300 hours *				
Water & Dust Exposure	Withstands water submergence and dust exposure per IP-68 *				
Vibration Test	2 Hours at 1.5 mm with 10 to 55 Hz. of vibration frequency to each of 3 perpendicular direction *				
Drop Test	Dropped naturally from 1 meter height onto the surface of 10mm wooden board, 2 directions upper and side of the part are applied *				
Termination Strength	Maximum of 15 pounds (6.8 Kg) load pull test and of 4 lb. per inch driving torque on screw				
* Reliability Test Performance	Parts should conform to original performance within ±3dB, after 3 hours of recovery and dry period				
Life Test	Intermittent	1,000 hours of a 1 minute on 4 minutes off cycle at room temperature and maximum rated voltage			
	Continuous	250 hours continuous operation at maximum rated Voltage and maximum Operating Temperatures			
Warranty	For a period of one (1) year from date of shipping under normal operations conditions This warranty does not apply to products damaged through misuse, abuse, improper installation, alteration, rework, or attempt to repair				

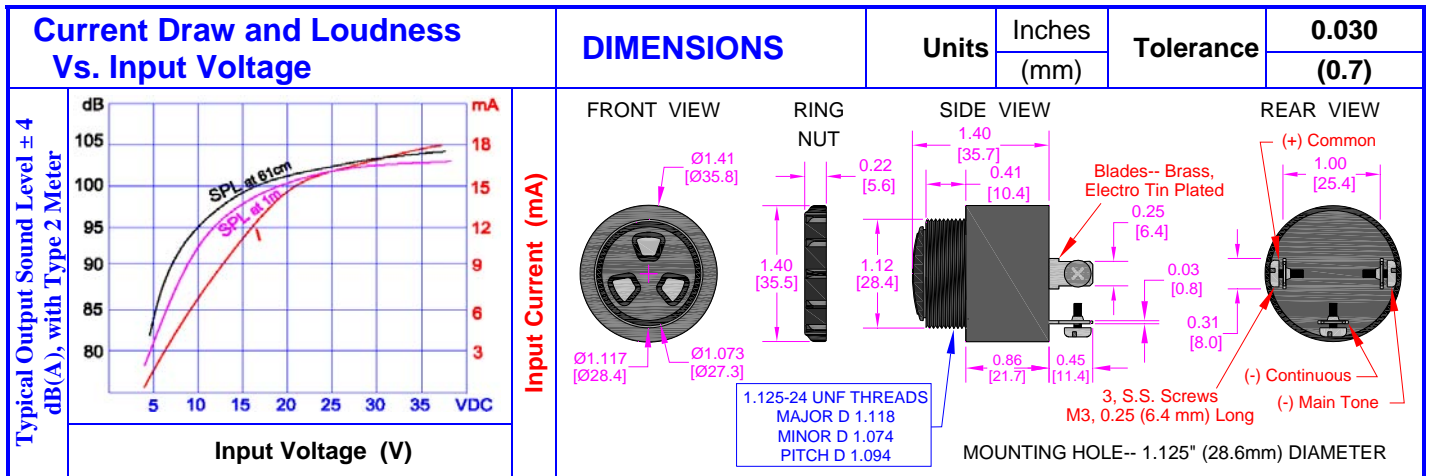

PACKAGING		MARKING		TRAY		
ONE TRAY: 	TWO BUNDLE 	Bundle	Dimensions		X1	34.7 cm
		Customer PN			Y1	34.7 cm
Other PN if required	Z1	21.2 cm				
Quantity		Quantity	42			
Lot and/or Date Code		BUNDLE				
Bundle Number		Dimensions		X2	cm	
Shipping Box				Y2	cm	
Customer Part Number				Z2	cm	
Other PN (if required)		Quantity				
Quantity		SHIPPING BOX				
Lot and/or Date Code		Dimensions		X3	35 cm	
PO Number				Y3	35 cm	
Net Weight				Z3	22.5 cm	
Gross Weight		Number of Bundles	1			
Box Number		Quantity	250			
of Number of Boxes		Approximate Weight	9 Kg.			
Made in China						

The information contained herein is believed to be correct, but no guarantee or warranty, express or implied, with respect to accuracy, completeness or results is extended and no liability is assumed.
 Challenge Electronics reserves the right to make changes in any specification, data or material contained herein.