

# CS15-01R115-04-1X

 Rev. 1-2026  
 RoHS3 & REACH  
 IPX7 Front Face  
 Mobile Speakers



## Operating Characteristics: 1cc Sealed Enclosure

### ELECTRICAL

Rated Power	1 W
Short Term Max Power	1.2 W
Impedance	8 Ω ± 20 % 2,000 Hz; 1 W

### ACOUSTIC

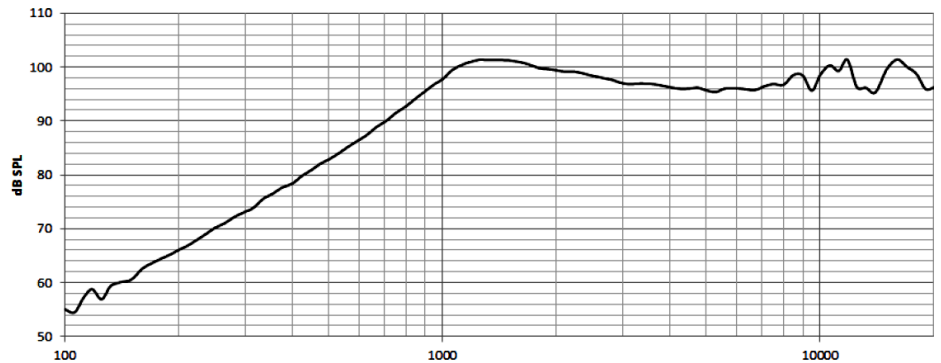
$f_0$	1,150 Hz ± 20 % 1 W
Freq. Range	920 to 20,000 Hz
Rated SPL	100 ± 3 dB 1,000, 1,180, 1,500 Hz; AVG; 1 W; 10 cm
Distortion	< 5 % 2,000 Hz; 1 W



## Physical Characteristics

### MATERIALS

Housing	PPA
Cone	PEEK
Magnet	NdFeB
Spring	Stainless Steel

### TEMPERATURE RANGES

Operating	-20 to +70 °C
Storage	-30 to +70 °C

Weight	2.6 g
--------	-------

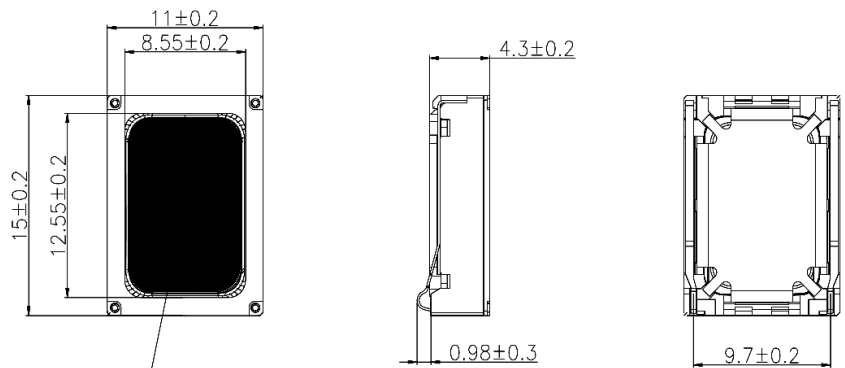

Black diaphragm

General tolerance = ±0.2 mm and all measurements in mm unless otherwise noted.

Revision	Description	By	Date
0-2026	Original Specification	KG	2026-01-15
1-2026	Updated to include TS Parameters and XMAX value.	KG	2026-04-23

Warranty: For a period of one (1) year from date of shipping under normal operations conditions. This warranty does not apply to products damaged through misuse, abuse, improper installation, alteration, rework, or attempt to repair.

The information contained herein is believed to be correct, but no guarantee or warranty, express or implied, with respect to accuracy, completeness or results is extended and no liability is assumed. Challenge Electronics reserves the right to make changes in any specification, data or material contained herein.

\*IP rating can be achieved through proper assembly mounting. Please contact your local Challenge Electronics sales representative for more details.

©2026 Challenge Electronics, Inc. Pub. 20260423163034

# CS15-01R115-04-1X

 Rev. 1-2026  
 RoHS3 & REACH  
 IPX7 Front Face  
 Mobile Speakers

## Thiele Small Parameters

Electrical Parameters	Value	Unit	Description
<i>Re</i>	5.97	Ohm	electrical voice coil resistance at DC
<i>Le</i>	0.026	mH	frequency independent part of voice coil inductance
<i>L2</i>	0.004	mH	para-inductance of voice coil
<i>R2</i>	0.27	Ohm	electrical resistance due to eddy current losses
<i>Cmes</i>	88.23	μF	electrical capacitance representing moving mass
<i>Lces</i>	0.19	mH	electrical inductance representing driver compliance
<i>Res</i>	3	Ohm	resistance due to mechanical losses
<i>fs</i>	1228.4	Hz	driver resonance frequency
Mechanical Parameters	Value	Unit	Description
<i>Mms</i>	0.057	g	mechanical mass of driver diaphragm assembly including air load and voice coil
<i>Mmd (Sd)</i>	0.055	g	mechanical mass of voice coil and diaphragm without air load
<i>Rms</i>	0.214	kg/s	mechanical resistance of total-driver losses
<i>Cms</i>	0.296	mm/N	mechanical compliance of driver suspension
<i>Kms</i>	3.38	N/mm	mechanical stiffness of driver suspension
<i>Bl</i>	0.802	N/A	force factor (Bl product)
<i>Lambda s</i>	0.439	N/A	suspension creep factor
Loss Factors	Value	Unit	Description
<i>Qtp</i>	1.359	N/A	total Q-factor considering all losses
<i>Qms</i>	2.04	N/A	mechanical Q-factor of driver in free air considering Rms only
<i>Qes</i>	4.067	N/A	electrical Q-factor of driver in free air considering Re only
<i>Qts</i>	1.359	N/A	total Q-factor considering Re and Rms only
Other Parameters	Value	Unit	Description
<i>Vas</i>	0.0005	l	equivalent air volume of suspension
<i>n0</i>	0.023	%	reference efficiency (2 pi-radiation using Re)
<i>Lm</i>	75.9	dB	characteristic sound pressure level (SPL at 1m for 1W @ Re)
<i>Ln0m</i>	77.17	dB	nominal sensitivity (SPL at 1m for 1W @ Zn)
<i>rmse Z</i>	2.49	%	root-mean-square fitting error of driver impedance Z(f)
<i>rmse Hx</i>	8.61	%	root-mean-square fitting error of transfer function Hx (f)
<i>Series resistor</i>	0	Ohm	resistance of series resistor
<i>Sd</i>	1.13	cm <sup>2</sup>	diaphragm area
<i>XMAX</i>	+0.3/-0.25	mm	maximum one-way linear excursion of a speaker cone before distortion increases

Revision	Description	By	Date
0-2026	Original Specification	KG	2026-01-15
1-2026	Updated to include TS Parameters and XMAX value.	KG	2026-04-23

Warranty: For a period of one (1) year from date of shipping under normal operations conditions. This warranty does not apply to products damaged through misuse, abuse, improper installation, alteration, rework, or attempt to repair.

The information contained herein is believed to be correct, but no guarantee or warranty, express or implied, with respect to accuracy, completeness or results is extended and no liability is assumed. Challenge Electronics reserves the right to make changes in any specification, data or material contained herein.

\*IP rating can be achieved through proper assembly mounting. Please contact your local Challenge Electronics sales representative for more details.

©2026 Challenge Electronics, Inc. Pub. 20260423163034