

CS28-02W220-05-1X

 Rev. 9-2026
 RoHS3 & REACH
 IP67
 Round Speakers



Operating Characteristics

ELECTRICAL

| | |
|----------------------|--------------------------------|
| Rated Power | 0.5 W |
| Short Term Max Power | 1 W |
| Impedance | 8 Ω ± 15 % 2000 Hz; 0.125 W |

ACOUSTIC: Baffle Board

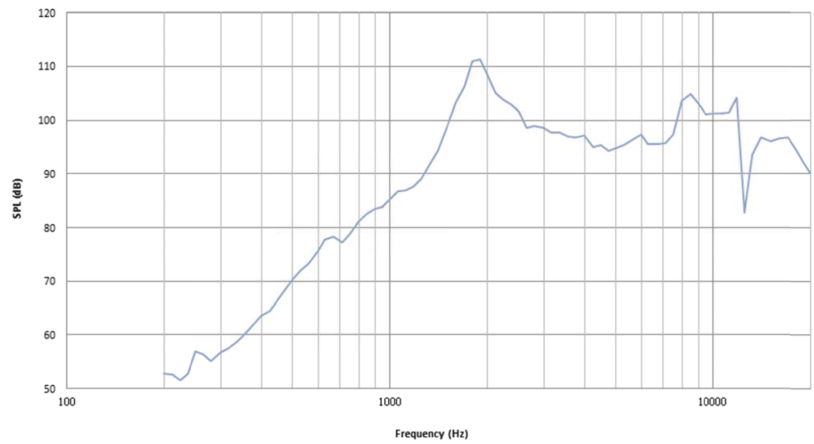
| | |
|-------------|---|
| f_0 | 2,200 Hz ± 20 % 0.125 W |
| Freq. Range | 1,760 to 10000 Hz |
| Rated SPL | 103 ± 3 dB 2000, 3000, 4000 Hz; AVG; 0.5 W; 10 cm |
| Distortion | Max 15 % 3000 Hz; 0.5 W |



Physical Characteristics

MATERIALS

| | |
|-----------|---------------------|
| Housing | Sealed Back SPCC |
| Cone | PEI |
| Magnet | NdFeB |
| Wire | UL1571, 28 AWG |
| Connector | Molex 51021-0200 |

TEMPERATURE RANGES

| | |
|-----------|---------------|
| Operating | -40 to +85 °C |
| Storage | -40 to +85 °C |

Weight 14.5 g

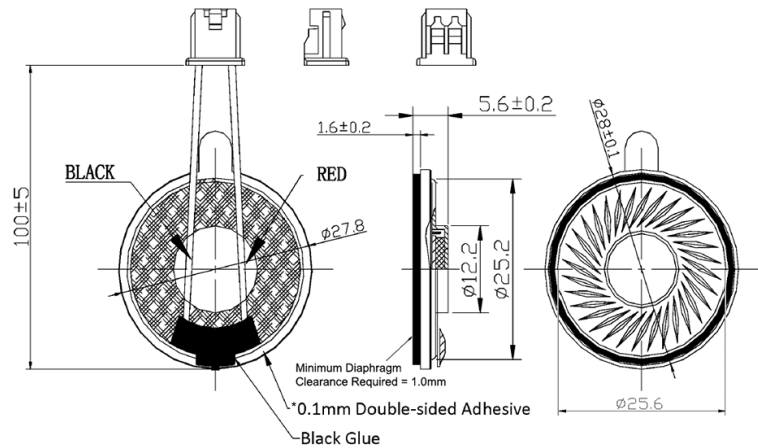

General tolerance = ±0.5 mm and all measurements in mm unless otherwise noted.

| Revision | Description | By | Date |
|----------|--|----|------------|
| 8-2024 | Updated frequency range. | SK | 2024-02-22 |
| 9-2026 | Updated to include TS Parameters and XMAX value. | KG | 2026-06-02 |

Warranty: For a period of one (1) year from date of shipping under normal operations conditions. This warranty does not apply to products damaged through misuse, abuse, improper installation, alteration, rework, or attempt to repair.

The information contained herein is believed to be correct, but no guarantee or warranty, express or implied, with respect to accuracy, completeness or results is extended and no liability is assumed. Challenge Electronics reserves the right to make changes in any specification, data or material contained herein.

CS28-02W220-05-1X

 Rev. 9-2026
 RoHS3 & REACH
 IP67
 Round Speakers

Thiele Small Parameters

| Electrical Parameters | Value | Unit | Description |
|------------------------|--------|-----------------|--|
| <i>Re</i> | 7.04 | Ohm | electrical voice coil resistance at DC |
| <i>Le</i> | 0.019 | mH | frequency independent part of voice coil inductance |
| <i>L2</i> | 0.002 | mH | para-inductance of voice coil |
| <i>R2</i> | 0.3 | Ohm | electrical resistance due to eddy current losses |
| <i>Cmes</i> | 260.35 | μF | electrical capacitance representing moving mass |
| <i>Lces</i> | 0.01 | mH | electrical inductance representing driver compliance |
| <i>Res</i> | 5.41 | Ohm | resistance due to mechanical losses |
| <i>fs</i> | 2740.4 | Hz | driver resonance frequency |
| Mechanical Parameters | Value | Unit | Description |
| <i>Mms</i> | 0.036 | g | mechanical mass of driver diaphragm assembly including air load and voice coil |
| <i>Mmd (Sd)</i> | 0.026 | g | mechanical mass of voice coil and diaphragm without air load |
| <i>Rms</i> | 0.025 | kg/s | mechanical resistance of total-driver losses |
| <i>Cms</i> | 0.094 | mm/N | mechanical compliance of driver suspension |
| <i>Kms</i> | 10.63 | N/mm | mechanical stiffness of driver suspension |
| <i>Bl</i> | 0.371 | N/A | force factor (Bl product) |
| <i>Lambda s</i> | -0.04 | N/A | suspension creep factor |
| Loss Factors | Value | Unit | Description |
| <i>Qtp</i> | 13.712 | N/A | total Q-factor considering all losses |
| <i>Qms</i> | 24.249 | N/A | mechanical Q-factor of driver in free air considering Rms only |
| <i>Qes</i> | 31.539 | N/A | electrical Q-factor of driver in free air considering Re only |
| <i>Qts</i> | 13.709 | N/A | total Q-factor considering Re and Rms only |
| Other Parameters | Value | Unit | Description |
| <i>Vas</i> | 0.0023 | l | equivalent air volume of suspension |
| <i>n0</i> | 0.144 | % | reference efficiency (2 pi-radiation using Re) |
| <i>Lm</i> | 83.79 | dB | characteristic sound pressure level (SPL at 1m for 1W @ Re) |
| <i>Ln0m</i> | 84.35 | dB | nominal sensitivity (SPL at 1m for 1W @ Zn) |
| <i>rmse Z</i> | 0.63 | % | root-mean-square fitting error of driver impedance Z(f) |
| <i>rmse Hx</i> | 4.32 | % | root-mean-square fitting error of transfer function Hx (f) |
| <i>Series resistor</i> | 0 | Ohm | resistance of series resistor |
| <i>Sd</i> | 4.15 | cm ² | diaphragm area |
| <i>XMAX</i> | 0.25 | mm | maximum one-way linear excursion of a speaker cone before distortion increases |

| Revision | Description | By | Date |
|----------|--|----|------------|
| 8-2024 | Updated frequency range. | SK | 2024-02-22 |
| 9-2026 | Updated to include TS Parameters and XMAX value. | KG | 2026-06-02 |

Warranty: For a period of one (1) year from date of shipping under normal operations conditions. This warranty does not apply to products damaged through misuse, abuse, improper installation, alteration, rework, or attempt to repair.

The information contained herein is believed to be correct, but no guarantee or warranty, express or implied, with respect to accuracy, completeness or results is extended and no liability is assumed. Challenge Electronics reserves the right to make changes in any specification, data or material contained herein.