

CS45-05D13-24-1X

 Rev. 2-2026
 RoHS3 & REACH
 IP67 Front Face
 Round Speakers



Operating Characteristics

ELECTRICAL

Rated Power	5 W
Short Term Max Power	6 W
Impedance	4 Ω ± 15 % 2000 Hz; 0.25 W

ACOUSTIC: Baffle Board

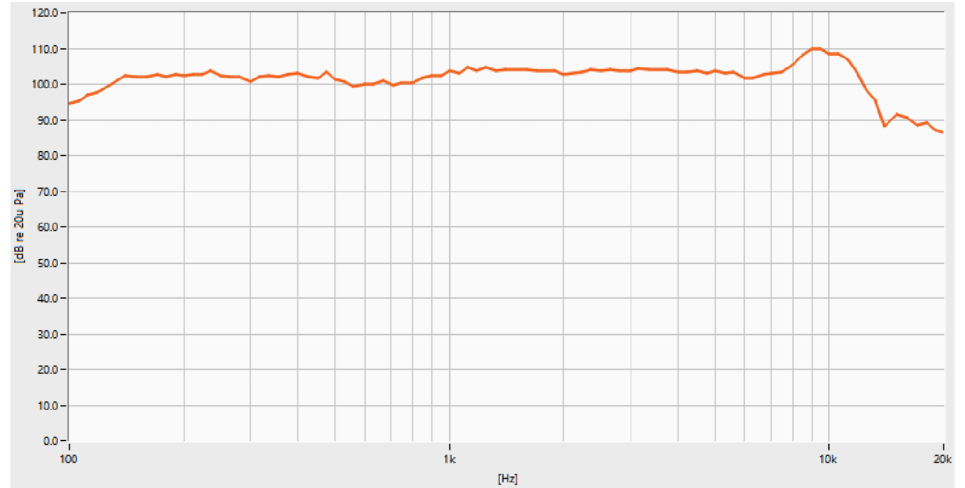
f_o	130 Hz ± 20 % 0.25 W; 10 cm
Freq. Range	104 to 20000 Hz
Rated SPL	104 ± 3 dB 800, 1000, 1200, 1500 Hz; AVG; 5 W; 10 cm
Distortion	Max 5 % 1000 Hz; 1 W



Physical Characteristics

MATERIALS

Housing	PBT
Cone	Rubber and PP
Magnet	NdFeB
Solder Tabs	Iron

TEMPERATURE RANGES

Operating	-40 to +85 °C
Storage	-40 to +85 °C

Weight 30 g

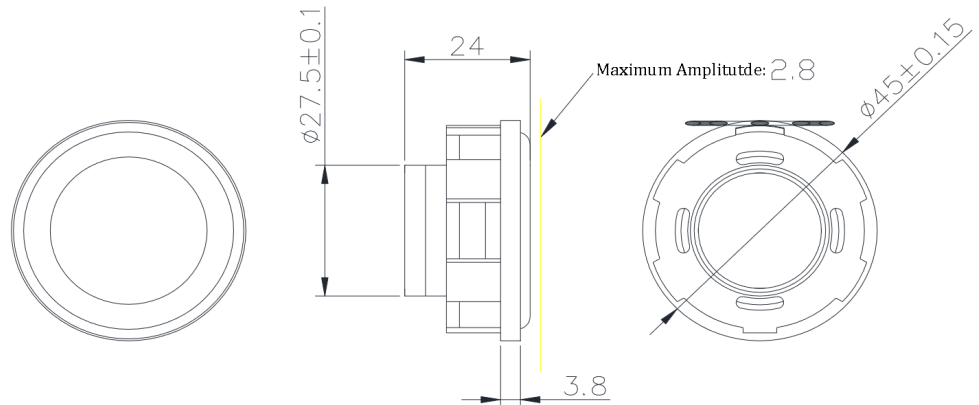

General tolerance = ±0.5 mm and all measurements in mm unless otherwise noted.

Revision	Description	By	Date
1-2024	Update from IP67 to IP67 Front Face.	JL	2024-08-13
2-2026	Updated to include TS Parameters and XMAX value.	KG	2026-04-20

Warranty: For a period of one (1) year from date of shipping under normal operations conditions. This warranty does not apply to products damaged through misuse, abuse, improper installation, alteration, rework, or attempt to repair.

The information contained herein is believed to be correct, but no guarantee or warranty, express or implied, with respect to accuracy, completeness or results is extended and no liability is assumed. Challenge Electronics reserves the right to make changes in any specification, data or material contained herein.

CS45-05D13-24-1X

 Rev. 2-2026
 RoHS3 & REACH
 IP67 Front Face
 Round Speakers

Thiele Small Parameters

Electrical Parameters	Value	Unit	Description
<i>Re</i>	3.64	Ohm	electrical voice coil resistance at DC
<i>Le</i>	0.047	mH	frequency independent part of voice coil inductance
<i>L2</i>	0.031	mH	para-inductance of voice coil
<i>R2</i>	0.93	Ohm	electrical resistance due to eddy current losses
<i>Cmes</i>	278.77	μF	electrical capacitance representing moving mass
<i>Lces</i>	3.14	mH	electrical inductance representing driver compliance
<i>Res</i>	17.31	Ohm	resistance due to mechanical losses
<i>fs</i>	150.1	Hz	driver resonance frequency
Mechanical Parameters	Value	Unit	Description
<i>Mms</i>	0.963	g	mechanical mass of driver diaphragm assembly including air load and voice coil
<i>Mmd (Sd)</i>	0.927	g	mechanical mass of voice coil and diaphragm without air load
<i>Rms</i>	0.2	kg/s	mechanical resistance of total-driver losses
<i>Cms</i>	0.909	mm/N	mechanical compliance of driver suspension
<i>Kms</i>	1.1	N/mm	mechanical stiffness of driver suspension
<i>Bl</i>	1.859	N/A	force factor (Bl product)
<i>Lambda s</i>	0.053	N/A	suspension creep factor
Loss Factors	Value	Unit	Description
<i>Qtp</i>	0.897	N/A	total Q-factor considering all losses
<i>Qms</i>	5.156	N/A	mechanical Q-factor of driver in free air considering Rms only
<i>Qes</i>	1.086	N/A	electrical Q-factor of driver in free air considering Re only
<i>Qts</i>	0.897	N/A	total Q-factor considering Re and Rms only
Other Parameters	Value	Unit	Description
<i>Vas</i>	0.1333	l	equivalent air volume of suspension
<i>n0</i>	0.058	%	reference efficiency (2 pi-radiation using Re)
<i>Lm</i>	79.84	dB	characteristic sound pressure level (SPL at 1m for 1W @ Re)
<i>Ln0m</i>	80.24	dB	nominal sensitivity (SPL at 1m for 1W @ Zn)
<i>rmse Z</i>	3.15	%	root-mean-square fitting error of driver impedance Z(f)
<i>rmse Hx</i>	1.22	%	root-mean-square fitting error of transfer function Hx (f)
<i>Series resistor</i>	0	Ohm	resistance of series resistor
<i>Sd</i>	10.18	cm ²	diaphragm area
<i>XMAX</i>	1.4	mm	maximum one-way linear excursion of a speaker cone before distortion increases

Revision	Description	By	Date
1-2024	Update from IP67 to IP67 Front Face.	JL	2024-08-13
2-2026	Updated to include TS Parameters and XMAX value.	KG	2026-04-20

Warranty: For a period of one (1) year from date of shipping under normal operations conditions. This warranty does not apply to products damaged through misuse, abuse, improper installation, alteration, rework, or attempt to repair.

The information contained herein is believed to be correct, but no guarantee or warranty, express or implied, with respect to accuracy, completeness or results is extended and no liability is assumed. Challenge Electronics reserves the right to make changes in any specification, data or material contained herein.