

INDICATORS • SPEAKERS • SOUND TRANSDUCERS • ENCLOSURES • MICROPHONES • BATTERY ACCESSORIES

## CS50-00D55-19-1

Former P/N: CES500R190AE8SMN550TR

Rev. 2-2019  
RoHS3 & REACH  
Round Speakers



### Operating Characteristics

#### ELECTRICAL

Rated Power	0.2 W
Short Term Max Power	0.4 W
Impedance	8 Ω ± 15 % 1000 Hz; 0.125 W

#### ACOUSTIC: Baffle Board

$f_0$	550 ± 110 Hz 0.125 W
Freq. Range	550 to 5500 Hz
Rated SPL	80 ± 3 dB 800, 1000, 1200, 1500 Hz; 1 W; 50 cm;
Distortion	>5 % 1000 Hz; 0.2 W

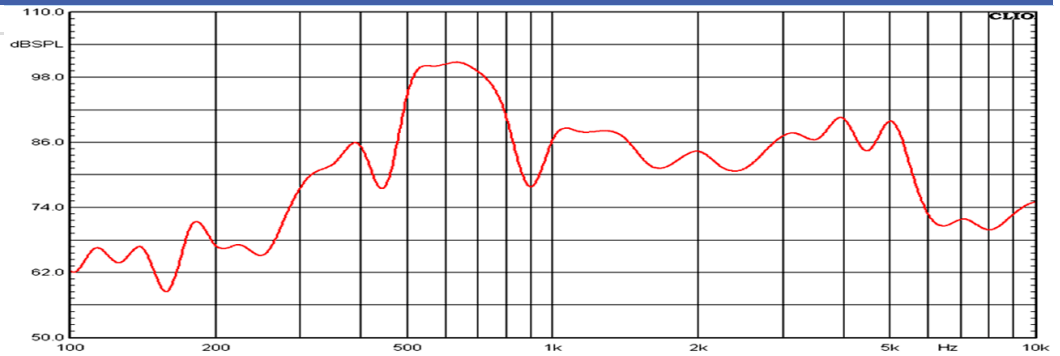

### Physical Characteristics

#### MATERIALS

Housing	Steel
Cone	Mylar
Magnet	NdFeB
Solder Tab	Tin Plated Brass

#### TEMPERATURE RANGES

Operating	-20 to +60 °C
Storage	-30 to +70 °C

Weight 31 g

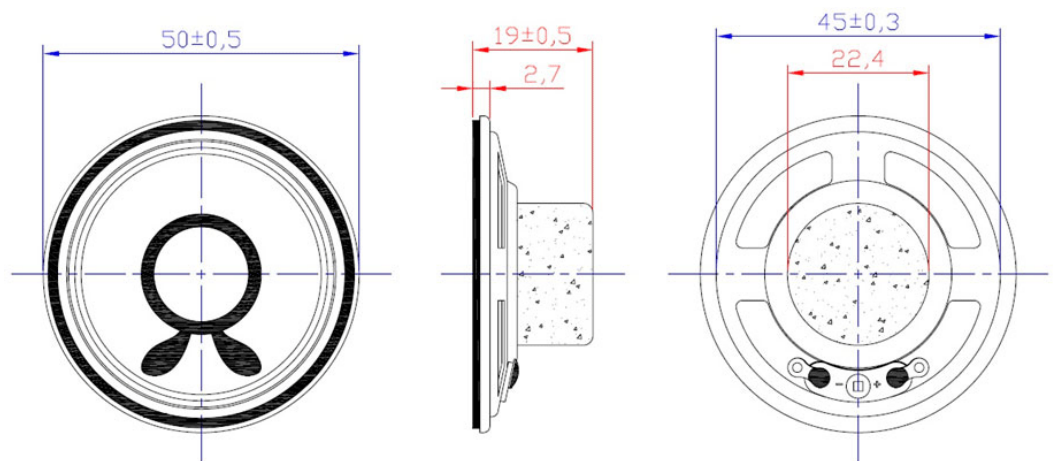

Revision	Description	By	Date
1-2014	Revised SPL, Resonant Frequency, Tolerance, and Humidity Test duration	WS	2014-03-24
2-2019	Migrate to new format	WS	2019-06-21

Warranty: For a period of one (1) year from date of shipping under normal operations conditions This warranty does not apply to products damaged through misuse, abuse, improper installation, alteration, rework, or attempt to repair.

The information contained herein is believed to be correct, but no guarantee or warranty, express or implied, with respect to accuracy, completeness or results is extended and no liability is assumed. Challenge Electronics reserves the right to make changes in any specification, data or material contained herein.

©2019 Challenge Electronics, Inc. 20190826155150